



Pelletizer

PT-G120D

PT-G220D

PT-G320D



Pelletizer PT-G120D G220D G320D

powerful

- double-sided bearings in an extremely robust forged stainless steel housing for high cutting gap stability
- cutting unit drive with powerful motor and frequency converter (short-term overload capacity up to 175%)
- noise enclosure hood and wear-protected intake already included in the standard
- stripper blade can be swivelled out without tools



variable due to many options

- intake section with separate drive motor and frequency converter for infinitive cutting length adjustment
- upper feed roller with separate drive, allows the use of a steel roller (instead of elastic)
- two power levels each for the cutting unit drive
- Cutting rotor 30 teeth, hardened tool steel or carbide
- optional interface to a higher-level controller (Industry 4.0 ready)

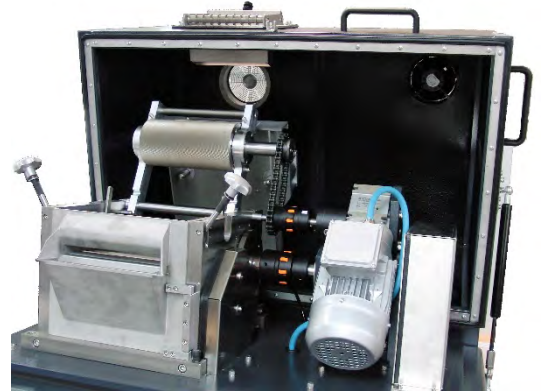

The pelletizer PT-GxxxD series are thus optimally equipped for the continuous production of filled and reinforced compounds or masterbatches from a wide variety of products.



Operating panel, with Touch-Display (optional)

Data:

	Pelletizer	PT-G120D	PT-G220D	PT-G320D
Working width	[mm]	120	220	320
No. of strands		max. 25	max. 55	max. 75
Throughput range	[kg/h]	max. 1000	max. 1500	max. 2000
Drive power	[kW]	5,5 / 7,5	7,5 / 11,0	11,0 / 15,0
Velocity	[m/min]		22,5 - 90 / 30 - 120	
Cutting tool mat.			S01 / H02	
Roller material			E01 / S02	
Roller pressure			pneumatically	
Sound level	[dB(A)]		<= 85	
Weight	[kg]	750	900	1100



Dimensions:

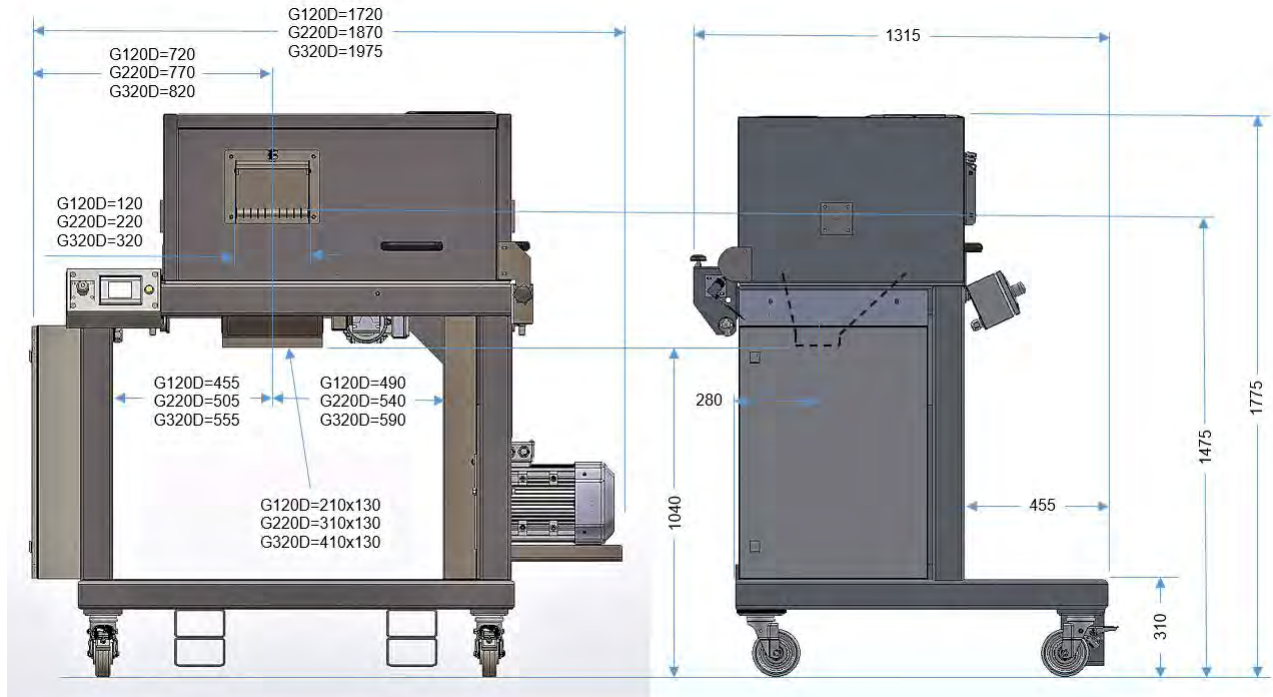

Throughput rates:

Pelletizer	PT-G120D				PT-G220D			PT-G320D		
	Velocity range [m/min]		22,5 - 90	30 - 120		22,5 - 90	30 - 120		22,5 - 90	30 - 120
Product	[g/cm ³]	Strands	Throughput [kg/h]		Strands	Throughput [kg/h]		Strands	Throughput [kg/h]	
PE/PP	0,92	25	878	1171	55	1931	2575	75	2634	3512
PS/ABS/SAN	1,05	25	1002	1336	55	2204	2939	75	3006	4008
ABS/PC	1,07	25	1021	1361	55	2246	2995	75	3063	4084
PA	1,13	25	1078	1438	55	2372	3163	75	3235	4313
PC/ABS	1,18	25	1126	1501	55	2477	3303	75	3378	4504
PC	1,20	25	1145	1527	55	2519	3359	75	3435	4580
MB P40	1,30	25	1241	1654	55	2729	3639	75	3722	4962
PBT/PET	1,33	20	1015	1354	40	2031	2708	60	3046	4061
PA GF30	1,36	20	1038	1384	40	2076	2769	60	3115	4153
PA GF50	1,56	20	1191	1588	40	2382	3176	60	3573	4764
PBT GF50	1,72	20	1313	1751	40	2626	3501	60	3939	5252

The stated throughput capacities are based on a strand diameter of 3.0 mm, the stated solids density of the respective plastic and maximum speed of the pelletizer. This does not take account of the procedural limits of the plastics to be processed.

Of course, the pelletizer could be completed with a suitable cooling trough, air knife and sifter forming a complete pelletizing line. The adaption of our equipment to existing pelletizing lines, as well as the delivery of special customized machinery will be executed flexible, quick and affordable.



About us:

The PT Maschinenbau GmbH is a privately owned company, located in southern Germany. As specialists in strand pelletizing we deliver our products from here to customers throughout whole Europe and worldwide.

We bundle up the core competencies for design, engineering and construction of our products. For the further provision of services we complement our abilities us by using a proven network of suppliers and service providers. We prefer generating our products by using local and European suppliers.



During decades of working in this business area we have gained a comprehensive experience, derived from countless projects with notable customers in all industry sectors and countries. Based on this know-how, with a long lasting and well-rehearsed team, we generate proven, reliable and durable solutions for our customers.

Scope of products:

Cooling		Drying		Cutting		Sifting
Cooling trough	Cooling belt	Strand conveyance	Water circulation	Air wipe Air knife	Pelletizer	Sifter
PT-K150	PT-B100	PT-C100	PT-W20	PT-D50	PT-G50E	PT-S150
PT-K200	PT-B200	PT-C200	PT-W40	PT-D100	PT-G100E	PT-S300
PT-K250	PT-B300	PT-C300	PT-W60	PT-A75	PT-G120D	PT-S400
PT-K400			PT-W90	PT-A150	PT-G220D	PT-S400-DD
PT-K600			PT-W120	PT-A300	PT-G320D	PT-S550-DD
PT-K800			PT-W150	PT-A400		
				PT-A600		

PT Maschinenbau GmbH
Schafweide 3
D-63762 Grossostheim

Telefon: +49-(0)6026-95180-04
Telefax: +49-(0)6026-95180-05
eMail: office@pt-maschinenbau.com

Information and illustrations refer to the date of printing.
Subject to change. Version 2.1 - 2018-01